

# MeasumaX

## Uni Micrometers

Micrometers are used to measure the outside diameters; inside diameters; the distance between parallel surfaces; the depth of holes, slots, counterbores, and recesses; and the distance from a surface to some recessed part. There are other uses of micrometers, but those mentioned here are uses you are most likely to encounter.

Whenever using an uni micrometer, carefully observe the following

1. Always open a micrometer by holding the frame with one hand and turning the knurled sleeve with the other hand.
2. Apply only moderate force to the knurled thimble when you take a measurement. Always use the ratchet thimble.

### Diagram 1

- |                    |                 |
|--------------------|-----------------|
| 1. Frame           | 2. Barrel       |
| 3. Ratchet Thimble | 4. Spindle Lock |
| 5. Spindle         | 6. Anvils       |

### Dimensions

- |                |                     |
|----------------|---------------------|
| 10-130 0-25mm  | A=28.5mm B= 0-25mm  |
| 10-131 25-50mm | A=53.5mm B= 25-59mm |

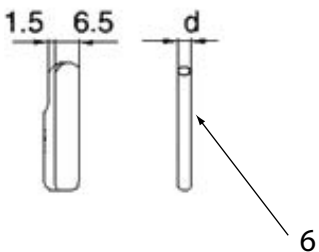
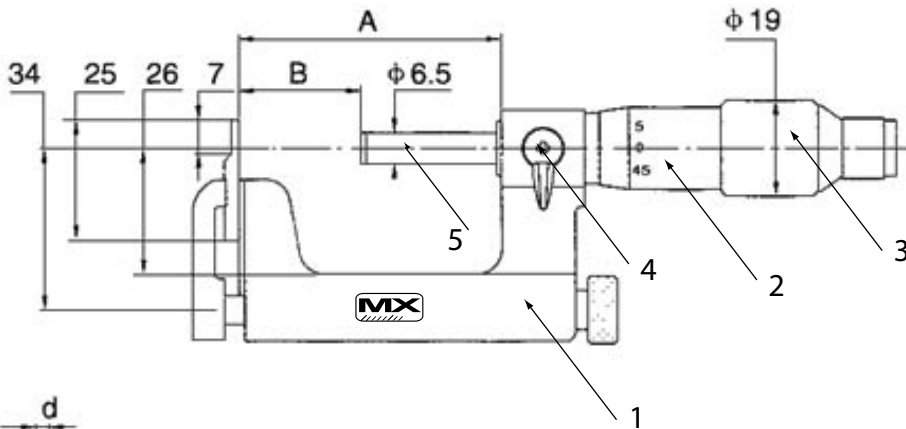

### Re-Setting the Micrometer

When the spindle is screwed closed on a 0-25mm micrometer, the reading should be zero. Use the spindle ratchet to obtain a light, even pressure. If the zero is slightly off it can be adjusted by turning the barrel into position. A special wrench is provided for this procedure.

For larger micrometers place the test bar provided between the anvils and using the spindle ratchet to obtain a light pressure, check to see if the micrometer reads zero.

### Maintenance

Before storing your MeasumaX micrometer, back the spindle away from the anvil, wipe all exterior surfaces with a clean, soft cloth, and coat the surfaces with a light oil. Should the spindle become loose adjustment can be made by tightening the nut at the end of the barrel until the action is smooth and easy.

“Measumax” micrometers are set and tested during production

